

Early age strength and workability of slag pastes activated by sodium silicates

F. Collins* and J. G. Sanjayan†

Monash University

This article reports the results of an investigation on the activation of blast furnace slag with emphasis on the achievement of equivalent one-day strength to Portland cement at normal curing temperatures and reasonable workability. The effects of varying dosages of sodium silicate activators are discussed in terms of strength of mini cylinders and also workability by the mini slump method. The results are mainly based on pastes but comparisons are also made with mortar and concrete results. The effects of preblended gypsum dosage within the slag, as well as the effect of ultra fine slag on workability are reported. The results of trials with various water reducing admixtures and superplasticisers and their effects on strength and workability are reported.

Introduction

Alkali activation of slag is a method to produce concrete with slag (ground granulated blastfurnace slag) without the use of any Portland cement. By substituting Portland cement with 100% alkali activated slag, a waste product of steel manufacturing, less energy is required while also achieving reduction in emissions arising from the burning of fossil fuels. Roy and Silsbee¹ and Talling and Brandstetr² provide a comprehensive summary of the subject.

Slag is often used in concrete as a supplementary cementitious material and partial replacement to Portland cement. The major advantages of making concrete with slag replacement is the superior durability and lower hydration heat as compared to a 100% Portland cement binder. It should be noted that with slag replacement, carbonation is increased, freeze–thaw resistance is reduced and, if slag is used at an appropriate level, sulphate resistance is reduced. The use of slag can also increase the risk of thermal cracking in concrete. However, the low early strength of these concretes is a limitation in many applications. The problem of low early strength can be overcome by

using alkali activated slag (AAS) concretes that can potentially yield high early strength.

The aim of this article was to evaluate the use of sodium silicate as an activator that would yield equivalent one-day strength to ordinary Portland cement at normal curing temperatures (23°C), while having reasonable workability. Equivalent one-day strength to Portland cement has been achieved using elevated temperature curing^{3–6} and steam curing.^{7–9} However, these curing conditions necessitate specialised equipment and facilities and requires attendance by staff. This study therefore concentrated on the achievement of equivalent one-day strength at normal curing conditions.

At normal curing conditions, Anderson and Gram⁷ achieved minimal one-day strength with slags activated by sodium silicate. Jolicoeur *et al.*⁸ found low one-day strength at dosages of 2% Na₂O, however at 4% Na₂O early strength increased with M_s (SiO₂/Na₂O, silicate modulus) increased from 0 to 0.5 and remained relatively constant with increasing M_s up to 2.0. At low M_s (0–0.5), the workability is low and loss of workability is rapid. For M_s between 0.5 and 1.5 the workability is high and loss of workability is minimal. The addition of lime increases the early strength development, however, for all the M_s longer-term strength is reduced and the workability is significantly reduced.

Douglas *et al.*⁹ found the activation of slag by sodium silicate solution with M_s 1.21, in combination with 2% lime and 1% Na₂SO₄ produced comparable mortar strength to Portland cement mortar. Concrete mixtures were subsequently manufactured with silicate

* Monash University, Clayton, Victoria 3168, Australia.

† Currently working at Maunsell McIntyre, Level 9, 161 Collins Street, Melbourne, Victoria 3000, Australia.

(MCR 887) Paper received 8 August 2000; last revised 29 January 2001; accepted 9 May 2001.

activator with M_s of 1.22, 1.36, 1.47 and w/c 0.34 to 0.48.^{10,11} The one-day strengths were generally high (mostly >20 MPa), with acceptable initial workability, however, workability was lost rapidly beyond 45 minutes.¹⁰

Xincheng *et al.*¹² reported one-day strengths as high as 68.1 MPa for slag activated by sodium silicate solution with M_s of 0.77, although the method of curing is unreported. Qing-Hua and Sarkar⁴ reported high one-day strength of slag pastes that contained a combination of liquid sodium silicate (5% Na₂O dosage) with SiO₂/Na₂O 1.5 in combination with 1.7% to 5.0% lime. The workability was found to decrease with increasing dosage of activator and the optimum lime dosage was found to be 2%. Use of lime successfully retarded the setting time.

Wang^{13,14} achieved high one-day strengths (up to 37.9 MPa) with use of liquid sodium silicates. The best alkali dosages were within the range 3.0–5.5% Na₂O by weight of slag and optimum range of M_s was 0.90 to 1.3 for neutral slag and 1.0 to 1.5 for basic slag. However, the time to initial set is significantly less than that of Portland cement, with many of the sodium silicate activators having a time to initial set less than 20 min. This is considered to be too short for most normal civil engineering applications.

Shi¹⁵ recorded better one-day strength than Portland cement mortars for slags activated by sodium silicate liquid with M_s of 1.5. The dosage of activator was 6% Na₂O.

Experimental programme

The chemical composition and properties of the cementitious binders are summarised in Table 1. The

binders used are ground granulated blast furnace slag (Slag), ultra-fine slag (UFS), Portland cement (OPC), and 50% ground granulated blast furnace slag + 50% Portland cement (GB 50/50). The term water/binder (w/b) ratio is used instead of the conventional water/cement ratio to include all the binders mentioned above. The slag is supplied with 2% gypsum which is blended with the slag.

The activators and adjuncts investigated were:

- Powdered sodium silicate (27% Na₂O, 54%SiO₂, 19% H₂O)
- Powdered sodium metasilicate (29% Na₂O, 28% SiO₂, 43% H₂O)
- Hydrated lime (L)

The two types of dry powdered silicate activators were blended in different proportions to yield different silicate moduli SiO₂/Na₂O (referred to as M_s). The dosages are expressed as 'Na' in the activator as a percentage of the weight of slag.

The hydrated lime is added to the mix in the form of a slurry. The slurry was added as a 50% lime plus 50% water mixture. Adjustments were made to the water added to the mixes to account for the free water contained in the slurry. The amount of lime added is expressed as a percentage of lime in total weight of the paste (referred to as %L in figures).

The chemical admixtures that were investigated were as follows:

NLSNS: normal life superplasticiser based on naphthalene sulphonates, which complies with ASTM C-494 type F.

WRSRL: water reducing and set retarding admixture based on lignosulphonates, which complies with ASTM C 494 Types B and D.

Table 1. Properties of cementitious materials

Constituent/Property	Slag	UFS	OPC	GB 50/50
SiO ₃ (%)	N/A	N/A	N/A	2.6
SiO ₂ (%)	35.04	33.2	19.9	26.4
Al ₂ O ₃ (%)	13.91	14.6	4.62	8.4
Fe ₂ O ₃ (%)	0.29	0.4	3.97	2.4
MgO (%)	6.13	5.5	1.73	3.6
CaO (%)	39.43	42.4	64.27	53.8
Na ₂ O (%)	0.34	0.3		
TiO ₂ (%)	0.42			
K ₂ O (%)	0.39	0.44	0.57	
P ₂ O ₅ (%)	<0.1			
MnO (%)	0.43			
Total Sulphur as SO ₃ (%)	2.43	0.2	2.56	
Sulphide Sulphur as S ²⁻	0.44			
Cl (p.p.m)	80			
Fineness (m ² /Kg)	460	1496	342	
Loss on ignition (%)	1.45		2.9	1.9
Time to initial set (hours)	N/A	N/A	2.0	2.45
Strength (MPa)	N/A	N/A		
3 days			32.7	22.2
7 days			42.0	36.0
28 days			54.1	59.1

In the case of mortars, the sand:cementitious binder ratio was 3:1. The sand was a locally produced river sand from Lynhurst. In the case of concrete, the aggregate/cement ratio was 5.44, and 42% of the total aggregate was fine aggregate, which consisted of the same type of sand used in mortars.

The size of the paste cylinders for compressive strength testing were 35 mm in diameter and 70 mm in length. The w/b ratio was fixed at 0.5 to enable reasonable paste workability. A total of six cylinders were tested for each data set. This phase tested the qualitative assessment of paste workability. Activated slag pastes that appeared to be considerably 'stiffer' than an OPC equivalent were therefore rejected for further assessment (regardless of the one-day strength).

Workability was assessed by the mini slump test, as reported by Kantro.¹⁶ The dimensions of the mini slump cone mould are: top diameter 19 mm, bottom diameter 38 mm, and height 57 mm (Fig. 1). The mould is placed firmly on a plastic sheet and filled with paste. The paste is tamped down with a spatula to ensure compaction. When the mould is full, the top surface is levelled and the excess paste is removed. The mould is removed vertically, ensuring no lateral disturbance, and the sample is left to harden over 24 hours.

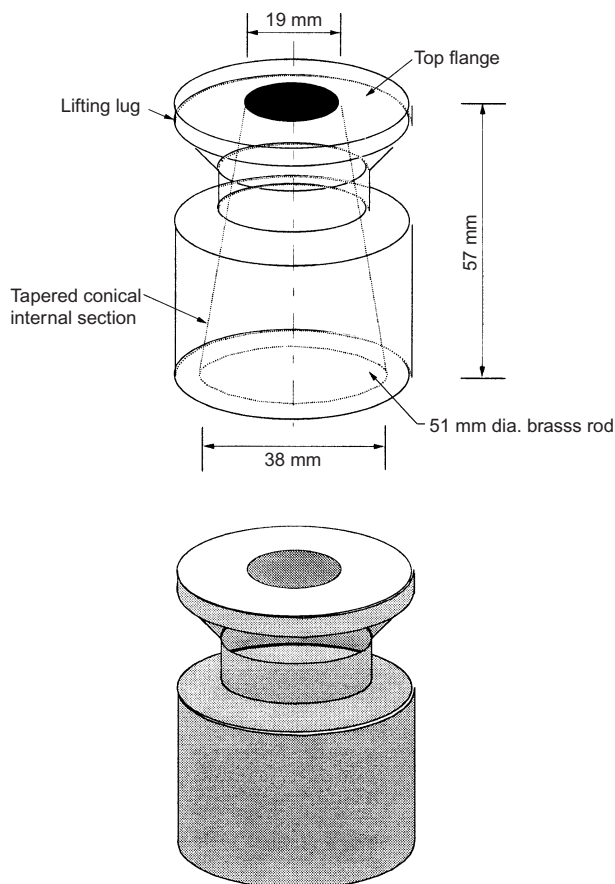

Fig. 1. Set-up for mini-slump test

The outline of the slump sample is traced onto the underlying plastic sheet with indelible ink and the area of the base is measured using a planimeter. Each data point shown on the attached figure is the average of three test results, with the exception of the OPC controls that were the average of six test results.

The base area of the paste measured 24 hours after conducting the test is a better indicator of workability than the height measurements.¹⁶ Perrenchio¹⁷ has established a linear relationship between the base area of the mini-slump paste and the base area of concrete; therefore the test lends itself to the estimation of likely concrete workability.

Strength results

The range of dosages investigated and one-day strength test results are summarised in Table 2. The results indicate the following:

- The one-day strength decreases with increasing M_s .
- The optimum M_s for one-day strength is likely to be less than 1.0. However, moduli less than 1.0 were unable to be investigated due to the limitations of the powdered silicates.
- The lime acts as an activator and significantly improves the one-day strength and, at 4% Na dosage, one-day strength increases with increasing lime content.

Further mixes were manufactured to assess the strength development with time. The mixes are 4% Na and 5% Na; $M_s = 1$ and 4% and 5% Na; $M_s = 1$; plus 1% lime slurry.

The results are summarised in Fig. 2. The results indicate the one-day strength of powdered sodium silicate (Na = 4%) is lower than OPC, however, at three days and beyond, the strength surpasses OPC. The 28-day strength of powdered silicate activated slags is similar regardless of Na concentration. With lime addition (which acts as a supplementary activator) the one-day strength is significantly greater (the lime also greatly assists with dispersion). The strength at later ages surpasses OPC. At 28 days, the strength of all the activated slags is almost identical, regardless of activator dosage and whether lime is present.

Strength development of mortars and concrete

The strength versus time graphs of pastes do not truly mimic the strength versus time relationship for concrete, as shown in Figs. 3 and 4. Further testing of mini cylinders has been conducted with mortars. The mixes consisted of:

- OPC, w/b = 0.5, three separate batches, six cylinders tested at 1, 3, 7 and 28 days;
- Slag activated by powdered sodium silicate + 1%

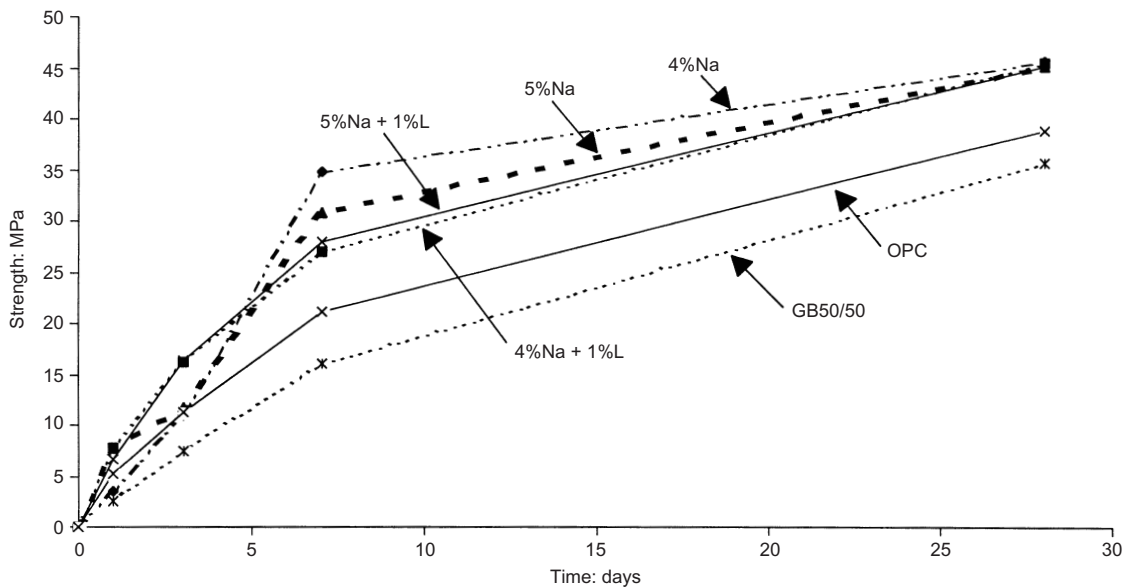

Fig. 2. Strength development of slag pastes; $w/b = 0.5$

Table 2. One-day strength of activated pastes (MPa)

Sodium Silicate Dosage (% Na)	Lime (% of total weight)	$M_s(\text{SiO}_2/\text{Na}_2\text{O}$ in activator)			
		1:0	1:3	1:5	1:8
4%	0	3.5	0.9	0.6	0
5%	0	7.7	1.9	0	0
6%	0	5.6	1.7	0	0
7%	0	8.7	8.8	7.8	
4%	1%	7.8			
4%	3%	10.3			
4%	5%	10.0			
5%	1%	6.6			

Portland cement paste = 5.2

lime (Na 4%, $M_s = 1$), $w/c = 0.5$, six cylinders tested at 1, 3, 7 and 28 days.

Figs. 3 and 4 indicate the mortars mimic the concrete strength development curves well. This indicates that the paste samples are very sensitive to local defects acting as stress concentrations. Also, the sand acts as nucleation points for cement hydration (and bond strength development), which also affect the measured strength. Nevertheless, the paste strength test results are good indicators of likely strength development trends.

Workability results

Without gypsum, the powdered sodium silicate activated slag showed an increase in workability. However, the one-day strength was zero. The literature indicates that gypsum plays a significant role in the very early hydration by breaking down the slag to enable further hydration and strength development to occur.⁶ Therefore, slag with gypsum was adopted.

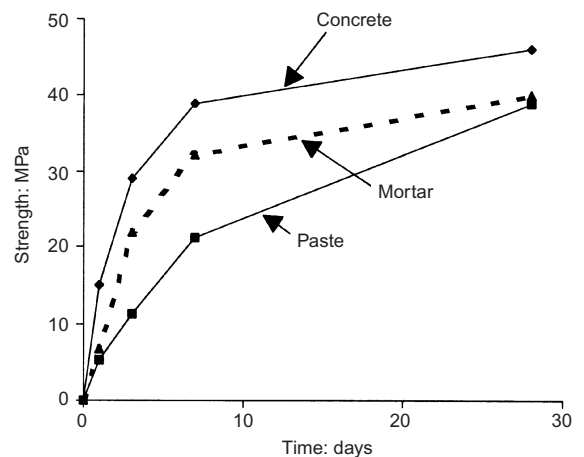

Fig. 3. OPC strength versus time: $w/b = 0.5$

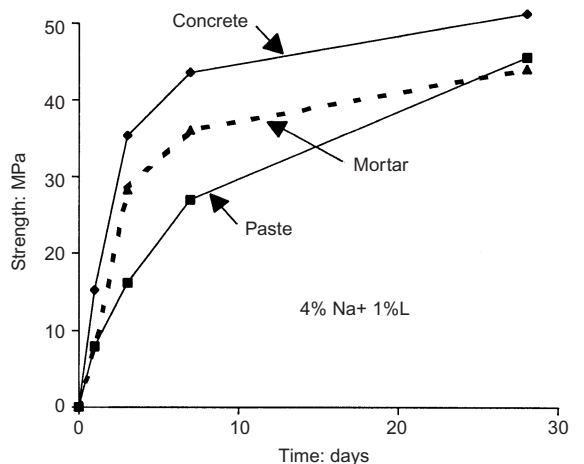

Fig. 4. AAS strength versus time: $w/b = 0.5$

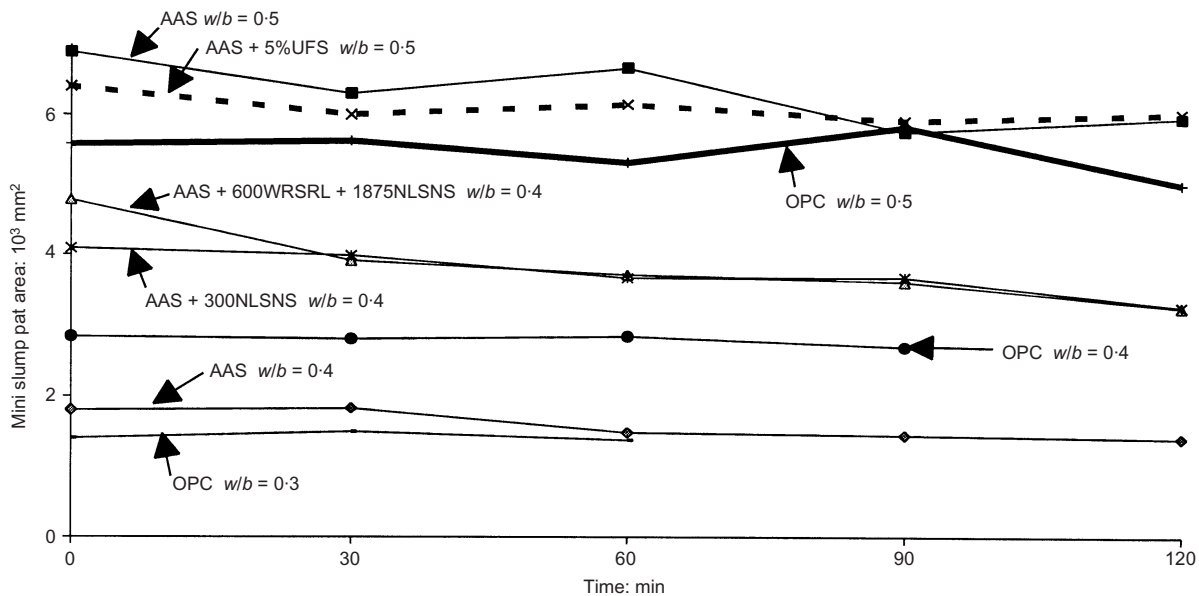

Fig. 5. Workability of pastes (dosages indicated in ml/100 kg slag) ($M_s = 1$; 4% Na + 1L)

At $w/b = 0.5$, Fig. 5 shows that AAS concrete shows better workability than OPC over 2 hours and there is no need for chemical admixtures. At $w/b = 0.4$, Fig. 5 shows the effect on workability at the time of mixing with additions of a lignosulphonate based water reducing retarder (WRSRL) and a normal life naphthalene sulphonate based superplasticiser (NLSNS).

Fig. 5 shows:

- Addition of lignosulphonate water reducing retarder (WRSRL) brings the workability up to the OPC control.
- Increasing additions of naphthalene sulphonate based superplasticiser (NLSNS) moderately improves workability, however the paste is not as workable as OPC with $w/b = 0.5$.
- Lignosulphonate water reducing retarder (WRSRL) + naphthalene sulphonate based superplasticiser (NLSNS) shows a significant improvement in workability (although still not as good as OPC $w/b = 0.5$).

Ultrafine slag replacement (5%) does not reduce the good workability over 2 hours and the workability is marginally better than OPC. At 10% replacement, the workability is identical at the time of mixing to 5% replacement, however, no data were acquired over 2 hours.

Conclusions

The results of this initial investigation indicate:

- Equivalent one-day compressive strength to OPC is achievable with 100% alkali activated slag.
- Powdered sodium silicate, with $\text{SiO}_2/\text{Na}_2\text{O}$ 1.0

Magazine of Concrete Research, 2001, 53, No. 00

and Na dosage 4% (% weight of slag) plus 1% lime yielded equivalent one-day strength to OPC and demonstrated better workability than OPC at $w/c = 0.5$. The one-day strength and workability decrease with increasing $\text{SiO}_2/\text{Na}_2\text{O}$ (or M_s).

- At $w/c = 0.4$ slag activated by powdered sodium silicate plus lime showed less workability than OPC controls and response to conventional superplasticisers was poor.
- Replacement of the slag by ultrafine slag did not reduce workability (at the 5% and 10% replacement levels).

Acknowledgements

The financial support for this project is jointly provided by Independent Cement and Lime Pty Ltd, Blue Circle Southern Cement Ltd, and Australian Steel Mill Services. The authors thank the sponsors especially Alan Dow, Tom Wauer, John Ashby, Wayne James, Katherine Turner and Dr. Ihor Hinczak for the guidance and support. The efforts and assistance with the laboratory work provided by Soon Keat Lim, Eric Tang, Jeff Doddrell, Roger Doulis, and Peter Dunbar are also gratefully acknowledged.

References

- ROY D. M. and SILSBEE M. R. Overview of slag microstructure and alkali – activated slag in concrete. *Proceedings of the 2nd CANMET/ACI International Symposium on Advances in Concrete Technology, Las Vegas, USA*, supplementary papers, 1995, pp. 699–716.
- TALLING B. and BRANDSTETR J. Present state and future of alkali-activated slag concretes. *Proceedings of the 3rd CANMET/ACI International Conference on Fly Ash, Silica Fume, Slag, and*

- Natural Pozzolans in Concrete, Trondheim, Norway*, ACI SP 114, Malhotra V. M. (ed), 1989, pp. 1519–1546.
3. GJORV O. E. Alkali activation of a Norwegian granulated blast furnace slag. *Proceedings of the 3rd CANMET/ACI International Conference on Fly Ash, Silica Fume, Slag, and Natural Pozzolans in Concrete, Trondheim, Norway*, ACI SP 114, Malhotra V. M. (ed) 1989, pp. 1501–1517.
 4. QING-HUA C. and SARKAR S. A study of rheological and mechanical properties of mixed alkali activated slag pastes. *Advanced Cement Based Materials*, 1994, **1**, 178–184.
 5. TALLING B. Effect of curing conditions on alkali-activated slags. *Proceedings of the 3rd CANMET/ACI International Conference on Fly Ash, Silica Fume, Slag and Natural Pozzolans in Concrete, Trondheim, Norway*, ACI SP 114, Malhotra V. M. (ed), 1989, pp. 1485–1500.
 6. HAKKINEN T. Properties of alkali-activated slag concrete. *Technical Research Centre of Finland Research Notes*, 1986, **540**, 62.
 7. ANDERSON R., GRAM H. E., MALOLEPSZY J. and DEJA J. Alkali-activated slag. *Swedish Cement and Concrete Institute Report 1.88.*, **9**, 1988.
 8. JOLICOEUR C., SIMARD M. A., TO T. C., SHARMAN J., ZAMOJSKA R., DUPUIS M., SPIRATOS N., DOUGLAS E. and MALHOTRA V. M. Chemical activation of blast-furnace slag: an overview and systematic experimental investigations. *Proceedings of the CANMET/ACI International Conference on Advances in Concrete Technology*, ACI SP-154, 1992 pp. 471–502.
 9. DOUGLAS E. and BRANDSTETR J. A preliminary study on the alkali-activation of ground granulated blast-furnace slag. *Cement and Concrete Research*, 1990, **20**, No. 5, 746–756.
 10. DOUGLAS E., BILODEAU A., BRANDSTETR J. and MALHOTRA V. M. Alkali activated ground granulated blast furnace slag concrete: preliminary investigation. *Cement and Concrete Research*, 1991, **21**, No.1, 101–108.
 11. DOUGLAS E., BILODEAU A. and MALHOTRA V. M. Properties and durability of alkali-activated slag concrete. *ACI Materials Journal*, 1992, **89**, No. 5, 509–516.
 12. XINCHENG P. *et al.* Structure and properties of high strength alkali slag concrete. *Proceedings of the Fourth International Conference on Fly Ash, Slag, and Natural Pozzolans in Concrete, Istanbul, Turkey*, 1992, ACI SP-132, 689–707.
 13. WANG S. D., SCIVENER K. L. and PRATT P. L. Factors affecting the strength of alkali-activated slag. *Cement and Concrete Research*, 1994, **24**, No. 6, 1033–1043.
 14. WANG S. D. Alkaline activation of slag. *PhD dissertation*, Imperial College of Science, Technology and Medicine, University of London, 1995.
 15. SHI C. Strength and pore structure and permeability of alkali-activated slag mortars. *Cement and Concrete Research*, 1996, **26**, No. 12, 1789–1799.
 16. KANTRO D. L. Influence of water reducing admixtures on properties of cement paste – a miniature slump test. *Cement, Concrete and Aggregates*, 1980, **2**, No. 2, 95–102.
 17. PERENCHIO W. F., WHITING D. A. and KANTRO D. L. Water reducer, slump loss and entrained air void systems as influenced by superplasticisers. *Proceedings of 1st International Symposium on Superplasticisers in Concrete*, ACI SP-62, 1978, pp. 137–155.

Discussion contributions on this paper should reach the editor by 1 February 2002